



Submersible Sewage Pump

MODEL 3886

WS_B Series

Prosurance available for residential applications.

APPLICATIONS

Specifically designed for the following uses:

- Homes
- Sewage systems
- Dewatering/Effluent
- Water transfer

SPECIFICATIONS

Pump:

- Solids handling capabilities: 2" maximum.
- Discharge size: 2" NPT.
- Capacities: up to 185 GPM.
- Total heads: up to 38 feet TDH.
- Temperature: 104°F (40°C) continuous 140°F (60°C) intermittent.
- See order numbers on reverse side for specific HP, voltage, phase and RPM's available.

FEATURES

- **Impeller:** Cast iron, semi-open, dynamically balanced, non-clog with pump out vanes for mechanical seal protection. Optional Silicon bronze impeller available.
- **Casing:** Cast iron volute type for maximum efficiency. Designed for easy installation on A10-20 guide rail.
- **Mechanical Seal: SILICON CARBIDE VS. SILICON CARBIDE** sealing faces for superior abrasive resistance, stainless steel metal parts, BUNA-N elastomers.
- **Shaft:** Corrosion-resistant stainless steel. Threaded design. Locknut on all models to guard against

component damage on accidental reverse rotation.

- **Fasteners:** 300 series stainless steel.
- Capable of running dry without damage to components.
- Designed for continuous operation when fully submerged.

MOTORS

- Fully submerged in high grade turbine oil for lubrication and efficient heat transfer. All ratings are within the working limits of the motor.
- **Class B insulation. Single phase (60 Hz):**
 - All single phase models feature capacitor start motors for maximum starting torque.

- Built-in overload with automatic reset.
- SJTOW or STOW severe duty oil and water resistant power cords.
- 1/3 – 1 HP models have NEMA three prong grounding plugs.

Three phase (60 Hz):

- Class 10 overload protection must be provided in separately ordered starter unit.
- STOW power cords all have bare lead cord ends.

- **Bearings:** Upper and lower heavy duty ball bearing construction.

- **Designed for Continuous Operation:** Pump ratings are within the motor manufacturer's recommended working limits, can be operated continuously without damage when fully submerged.

- **Power Cable:** Severe duty rated, oil and water resistant. Epoxy seal on motor end provides secondary moisture barrier in case of outer jacket damage and to prevent oil wicking. Standard cord is 20'. Optional lengths are available.

- **Motor Cover O-ring:** Assures positive sealing against contaminants and oil leakage.

AGENCY LISTINGS



Tested to UL 778 and CSA 22.2 108 Standards By Canadian Standards Association File #LR38549

Goulds Pumps is ISO 9001 Registered.

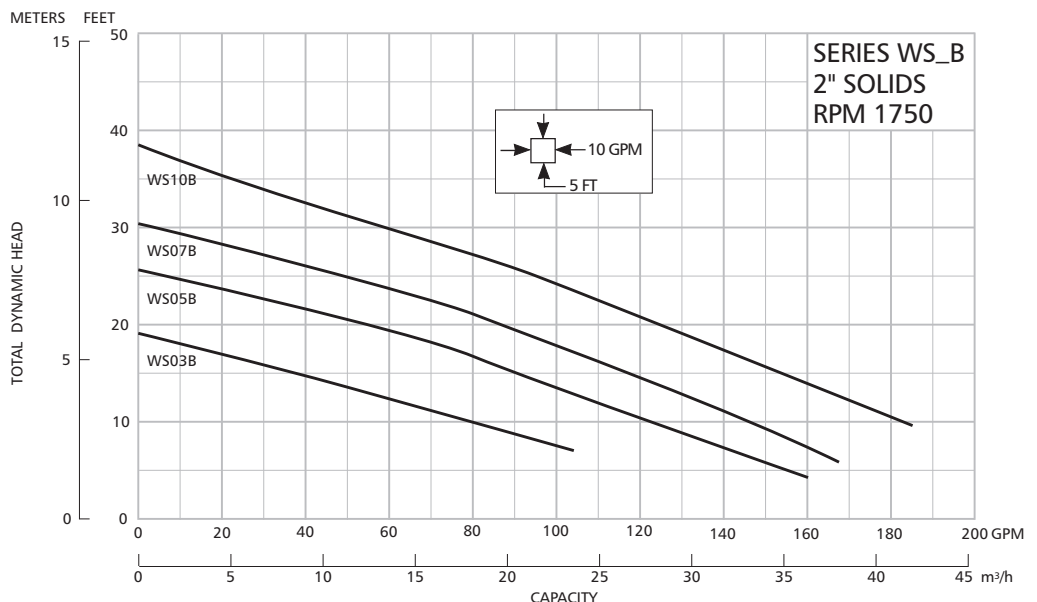

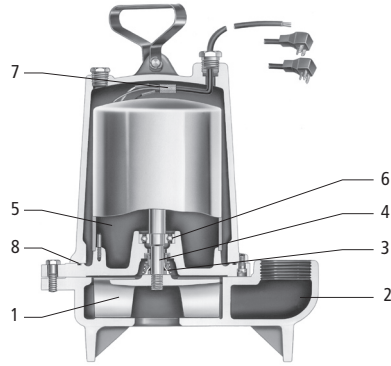

COMPONENTS

Item No.	Description
1	Impeller
2	Casing
3	Mechanical Seal
4	Motor Shaft
5	Motor
6	Ball Bearings
7	Power Cable
8	Casing O-Ring

DIMENSIONS

(All dimensions are in inches. Do not use for construction purposes.)

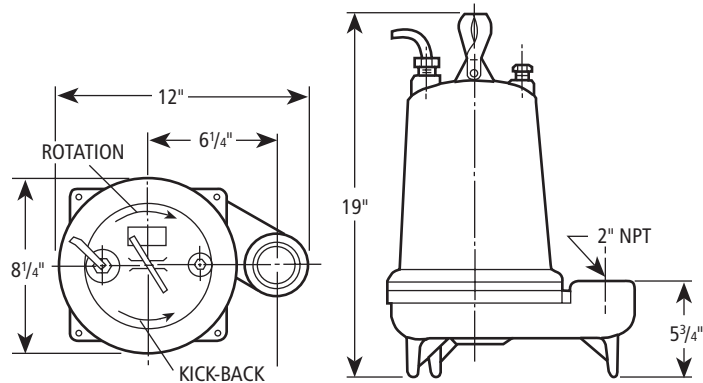

MODELS

Order No.	HP	Phase	Volts	Max Amps.	RPM	Wt. (lbs.)			
WS0311B	1/3	1	115	10.7	1750	63			
WS0318B			208	6.8					
WS0312B			230	4.9					
WS0511B	1/2	1	115	14.5		1750	65		
WS0518B			208	8.0					
WS0512B			230	7.3					
WS0538B	1/2	3	200	3.8			1750	65	
WS0532B			230	3.3					
WS0534B			460	1.7					
WS0537B	1/2	3	575	1.4				1750	65
WS0718B			208	11.0					
WS0712B			230	9.4					
WS0738B	3/4	3	200	4.1	1750				85
WS0732B			230	3.6					
WS0734B			460	1.8					
WS0737B	3/4	3	575	1.5		1750			85
WS1018B			208	14.0					
WS1012B			230	12.3					
WS1038B	1	1	200	6.2			1750		85
WS1032B			230	5.8					
WS1034B			460	2.9					
WS1037B	1	3	575	2.4				1750	85

PERFORMANCE RATINGS (gallons per minute)

Order No.	WS03B	WS05B	WS07B	WS10B
HP ▶	1/3	1/2	3/4	1
RPM ▶	1750	1750	1750	1750
Total Head Feet of Water	10 ▶	80	122	145
	15	36	90	116
	20	—	50	86
	25	—	—	48
	30	—	—	—
	35	—	—	—

Goolds Pumps is a brand of ITT Water Technology, Inc. – a subsidiary of ITT Industries, Inc.

Goolds Pumps and the ITT Engineered Blocks Symbol are registered trademarks and tradenames of ITT Industries.