



American Concrete Industries

750 Low-Boy Dual Comp. Grease Trap

Catalog Section:

Layout Name:

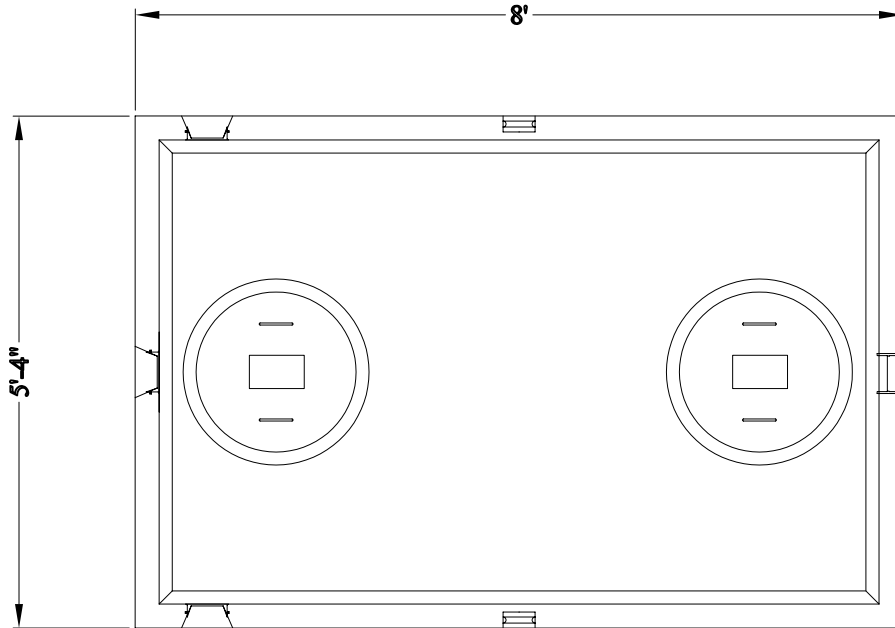

Plan View

General Notes

Concrete Specifications:

4000 psi after 28 days

%-6 % entrained air

Reinforcing is grade 60

Tank penetrations are integrally cast

Designed for HSS-10 wheel loading

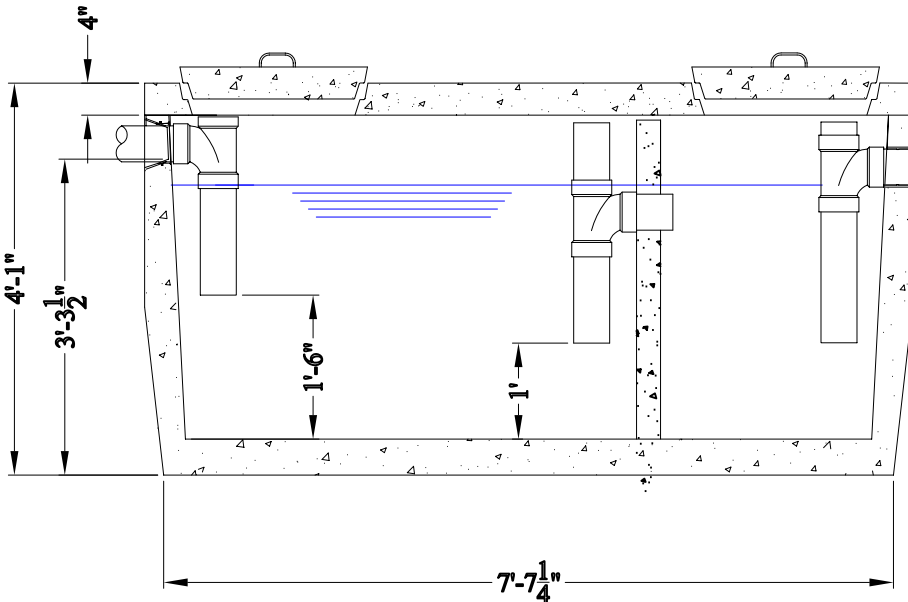

Joint sealed with $\frac{1}{2}$ " X $1\frac{1}{2}$ " butyl rubber seal. All tanks should be plant sealed for best results.

4" PVC coupling accepts SCH 40, SDR 35 or S & D pipe. All pipe types should be glued.

Section A-A

750 Gallon Top Seam Lowboy Dual Compartment Grease Trap

Item #8813 Weight: lbs.