

Three Phase Transformer Pad - Bangor Hydro

75 KVA to 1000 KVA

Pad Item # 5730 – WT: 14,935 lbs.

General Notes

Concrete Specifications:

- 1) 4000 psi after 28 days with 4%–6% air
- 2) Reinforcing is grade 60
- 3) Designed for H-20 Wheel Loading
- 4) Conforms to Bangor Hydro Specifications.

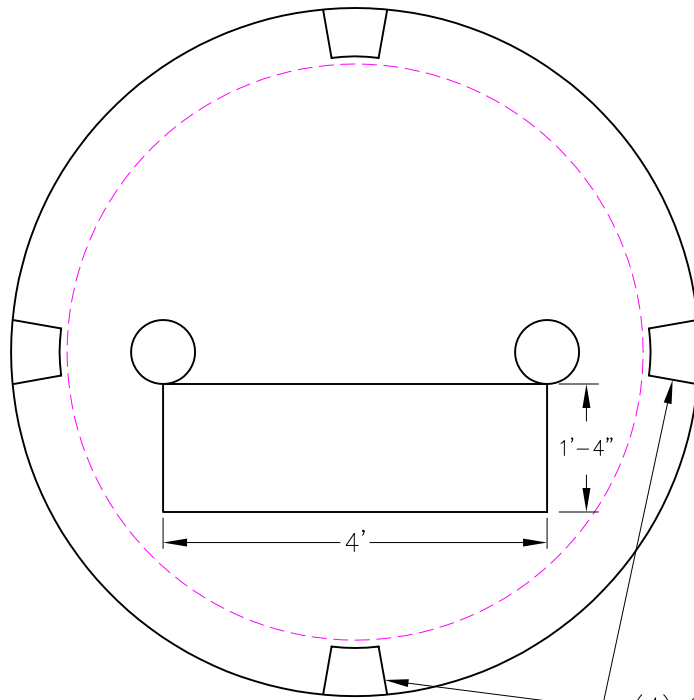

Plan View

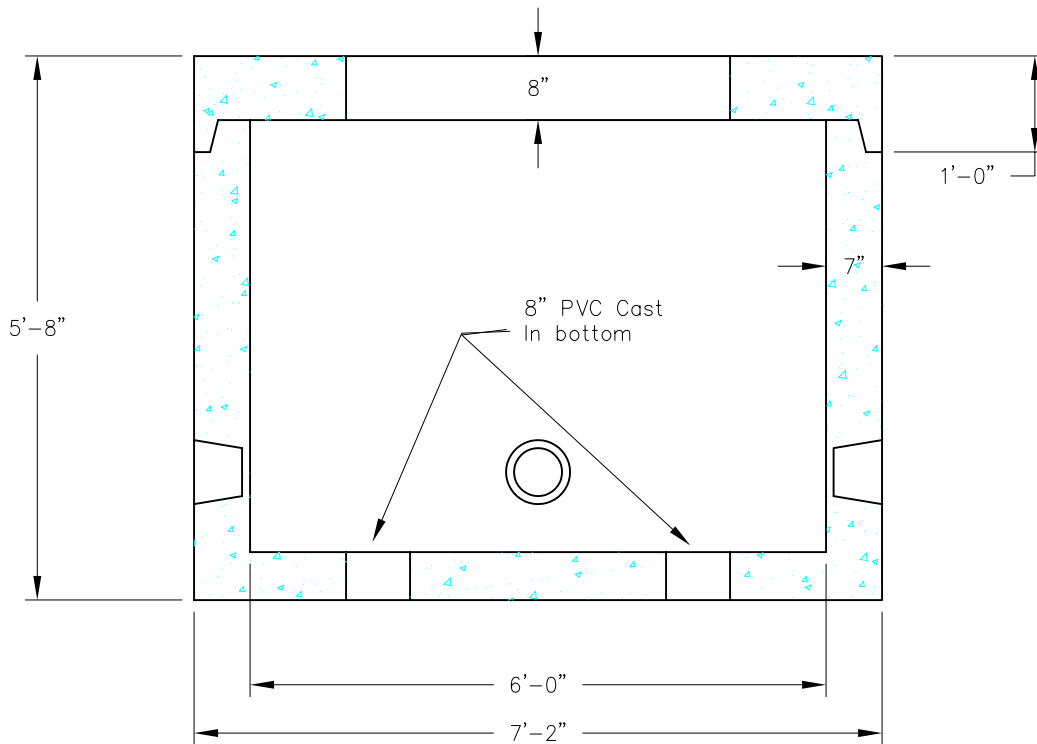

Section View



American Concrete Industries

1022 Minot Ave. Auburn, ME / 1717 Stillwater Ave. Veazie, ME
Tel: 207-784-1388 / Tel: 207-947-8334

Last Revised:
04/06

PG. XXX