

### 3 Phase Transformer Pad 9'x9'- CMP

Pad Item # 5737 – WT: 16,500 lbs.

Cover Item – WT: 1,100 lbs.

#### General Notes

##### Concrete Specifications:

- 1) 4000 psi after 28 days with 4%–6% air
- 2) Reinforcing is grade 60

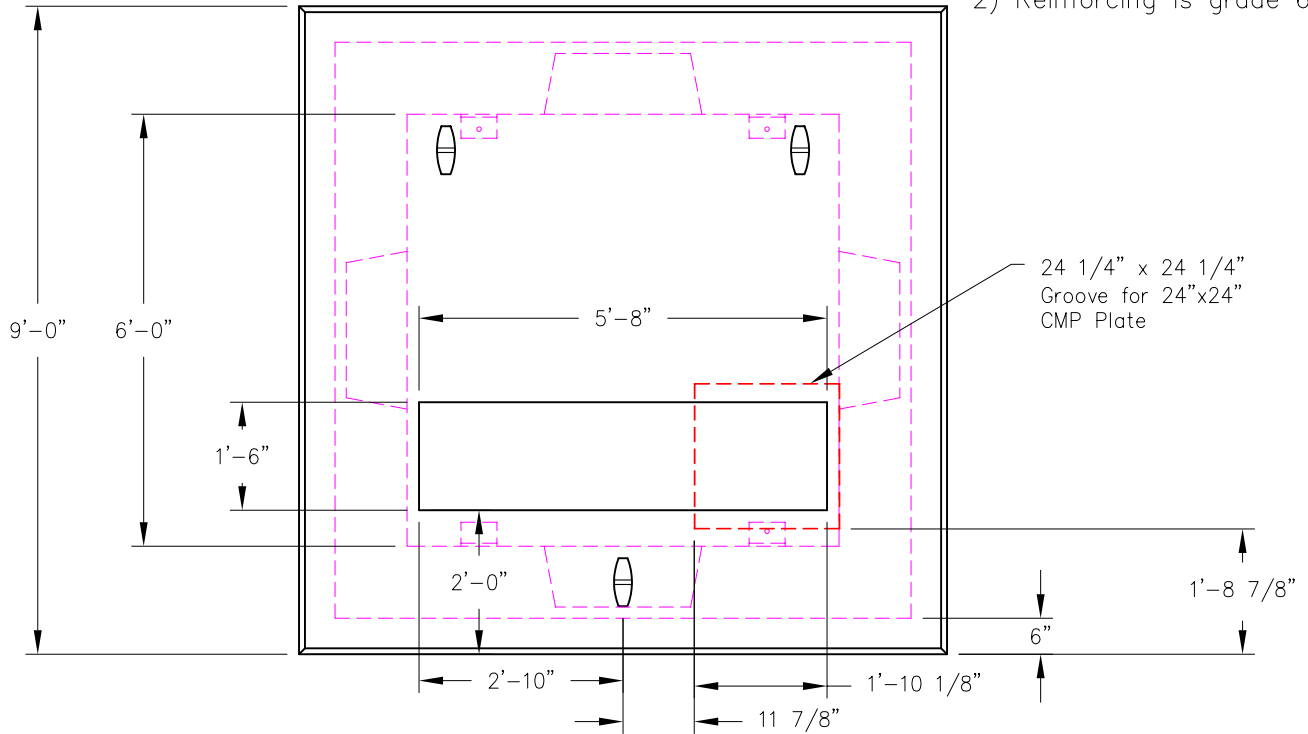

Plan View

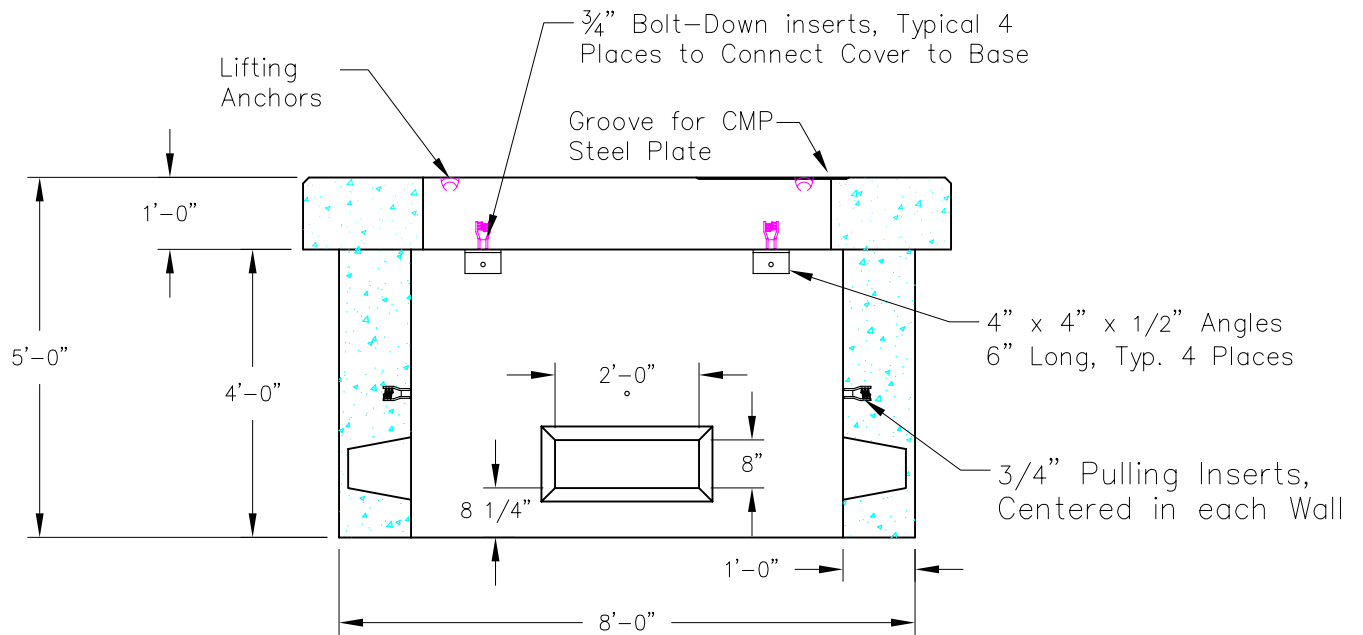

Section View



# American Concrete Industries

1022 Minot Ave. Auburn, ME / 1717 Stillwater Ave. Veazie, ME  
Tel: 207-784-1388 / Tel: 207-947-8334

Last Revised:  
03/06

PG. XXX