

3 Outlet Distribution Box

Weight: 87 lbs
Item # 2892

General Notes

Concrete Specifications:

- 1) 4000 psi after 28 days with 4%–6% air
- 2) Reinforcing is grade 60
- 3) Cover not designed for vehicle loads.
- 4) All penetrations to distribution boxes are integrally cast
- 5) Box should be covered with 2" Styrofoam Insulation

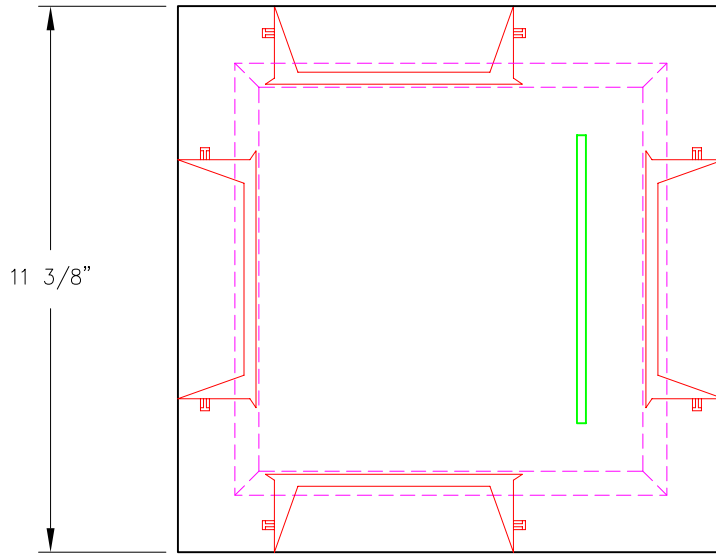

Plan View

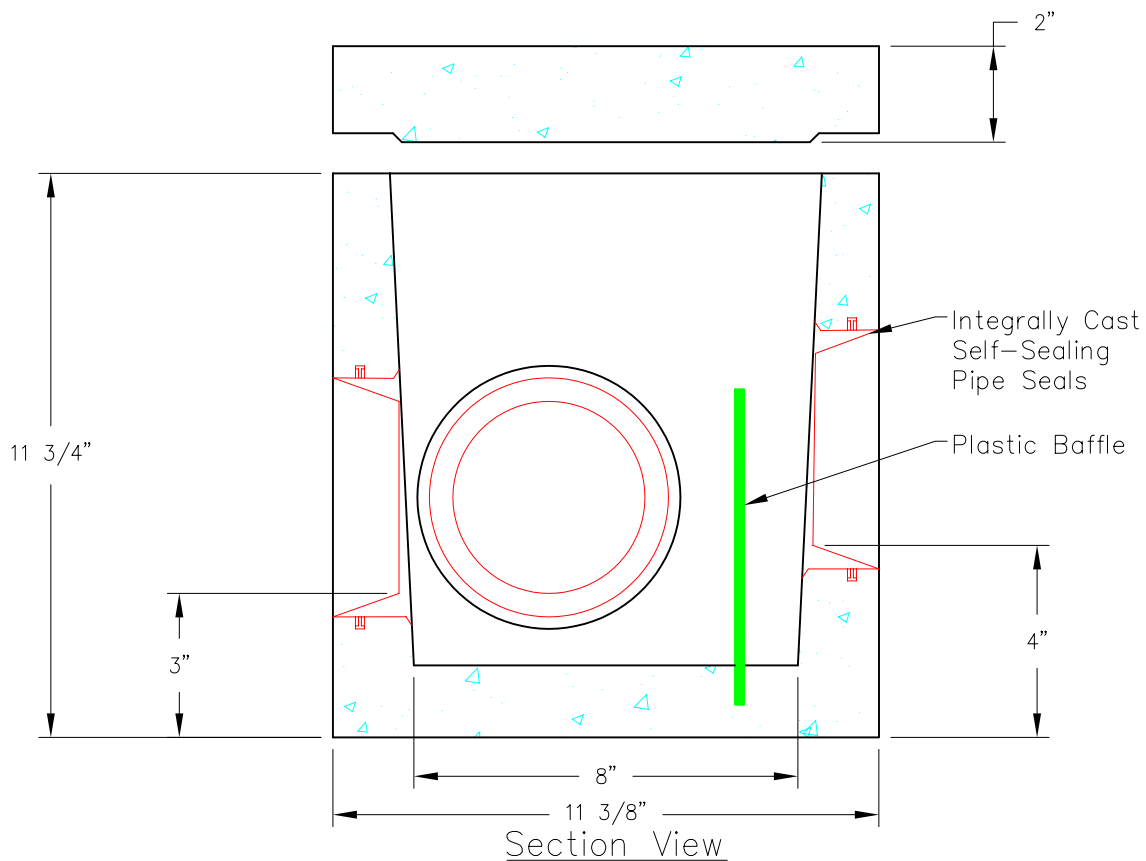

Section View



American Concrete Industries

1022 Minot Ave. Auburn, ME / 1717 Stillwater Ave. Veazie, ME
Tel: 207-784-1388 / Tel: 207-947-8334

Last Revised:
01/06

PG. XXX