

# 1000 Gallon Lowboy Lift Station

Weight: 10,100 lbs.  
Item # 1821

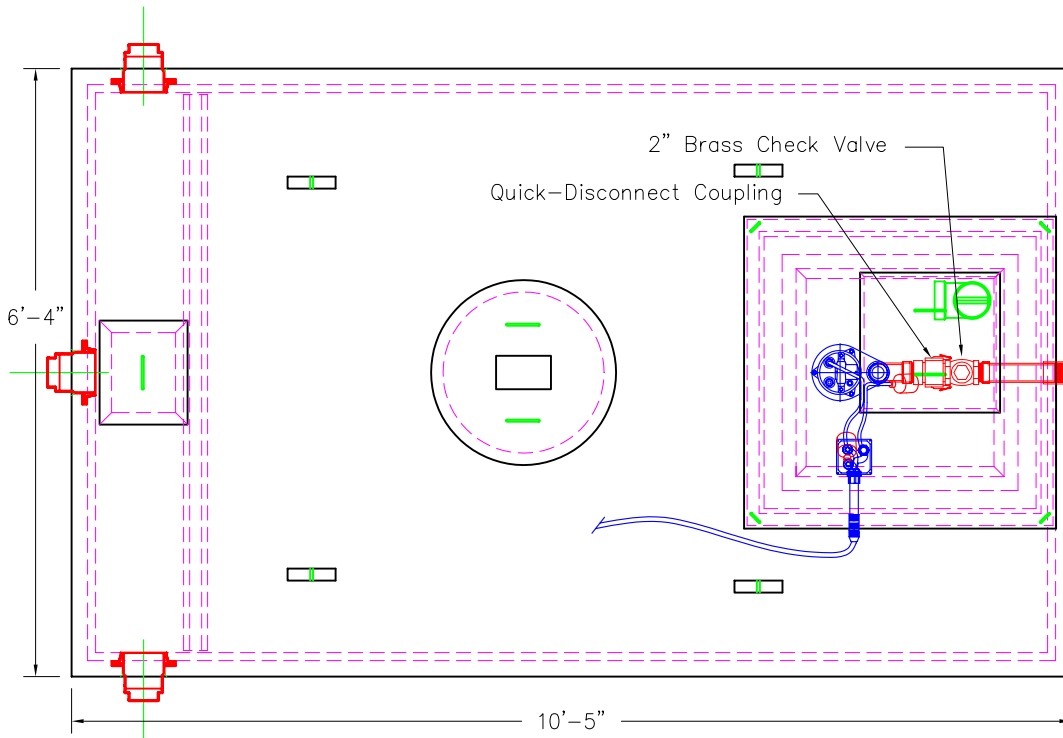

Plan View

## General Notes

### Concrete Specifications:

- 1) 4000 psi after 28 days with 4%-6% air
- 2) Reinforcing is grade 60
- 3) Cover over pump chamber is not designed for vehicle loads.
- 4) All joints sealed with butyl rubber joint sealant

### Septic Tank Information:

- 1) Tanks should be pumped every 3-5 years
- 2) Center access cover and pump chamber cover have risers to bring cover access close to grade.

### Pump System Information:

- 1) Pumps are warranted for one year from date of installation.
- 2) System includes ACI Alarm Panel for mounting inside building.
- 3) Available with longer cable. Please specify length when ordering.

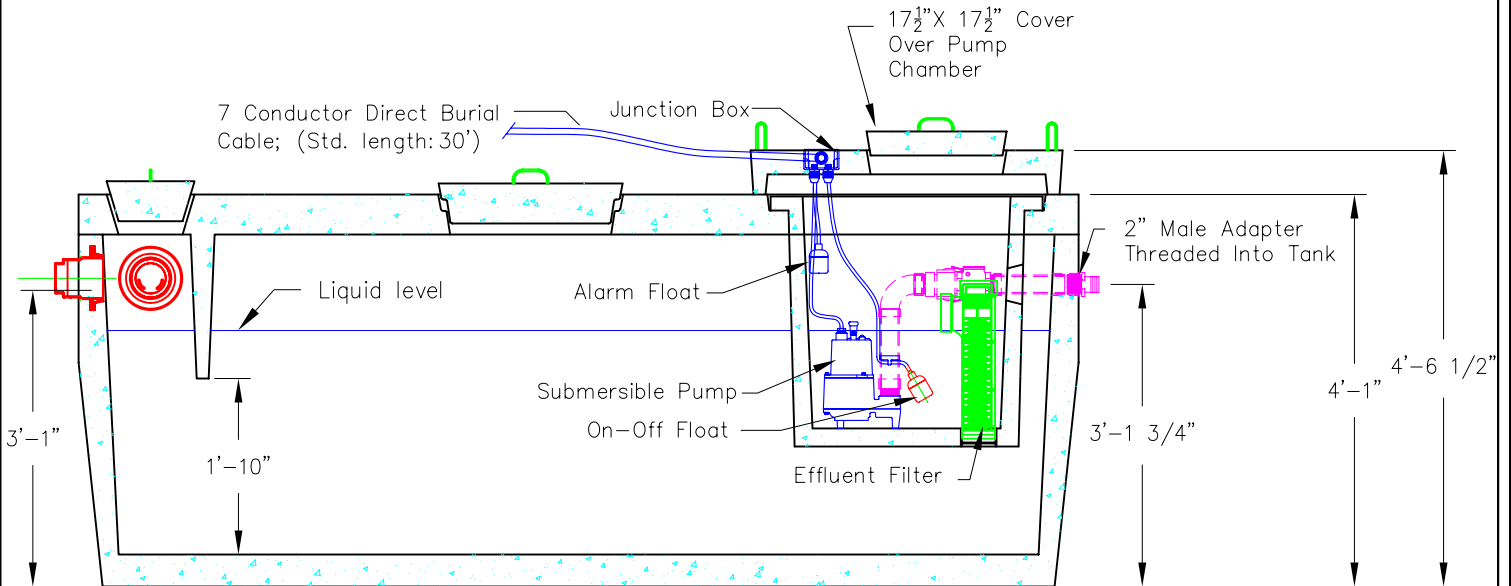

Section View

Item #	Pump Model
1821	Goulds PE51M
1823	Goulds WE0511HH
1824	Goulds WE0512HH
1825	Goulds WE1012H



# American Concrete Industries

1022 Minot Ave. Auburn, ME / 1717 Stillwater Ave. Veazie, ME  
Tel: 207-784-1388 / Tel: 207-947-8334

Last Revised:  
01/06

PG. XXX