



# American Concrete Industries

3' x 3' Pump Tank Plastic Cover

Catalog Section: Residential Pump Tanks

Layout Name: Catalog Vertical

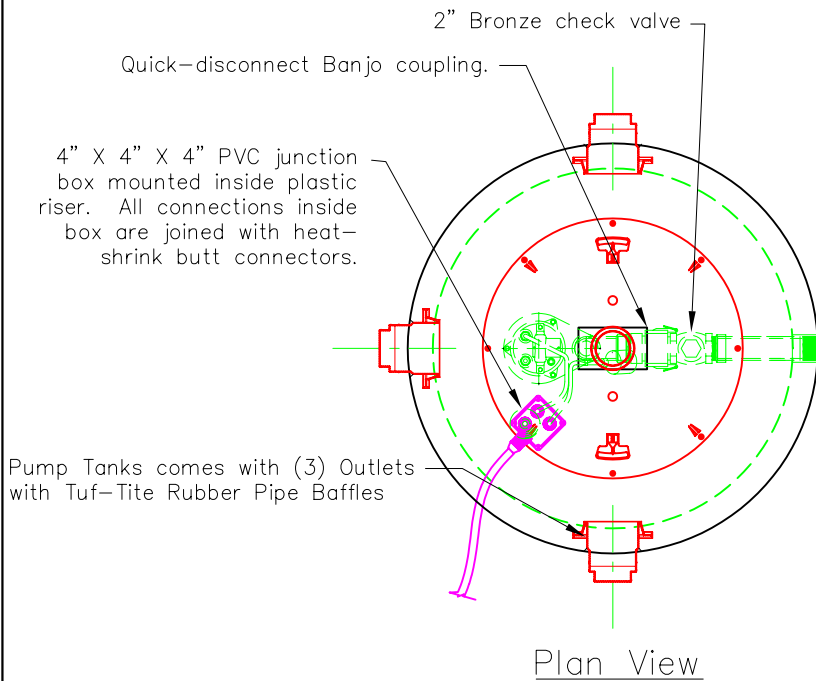

## General Notes

### Concrete Specifications:

4000 psi after 28 days with 4%-6% air  
Reinforcing is grade 60  
Cover is not designed for vehicle loads.

### Pump System Information:

Pumps are warranted for one year from date of installation.  
System includes ACI Alarm Panel for mounting inside building. Panel needs to be connected to a single 20 amp circuit breaker. Available with longer cable. Please specify length when ordering.

Plastic riser and watertight cover cast into top. 24" Clear opening.

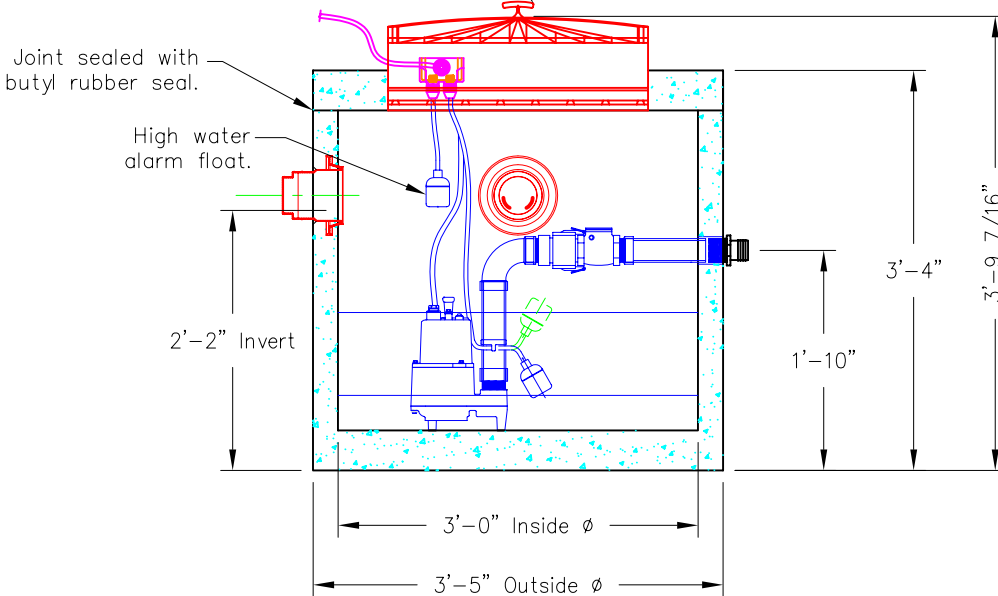

Section "A-A"

3' x 3' Pump Tank

Weight: 1650 lbs.

### Pump Tank Alone, (No Pump)

Item #	Description
1700P	Pump Tank and Cover
1700P-C	Cover Only

### With Effluent (3/4" Solids) Pump

Item #	Pump Model
1701P	Goulds PE51M
1702P	Goulds WE0511HH
1703P	Goulds WE0512HH
1704P	Goulds WE1012H

### With 2" Solids Handling Pumps

Item #	Pump Model
1706P	Goulds PS51M
1707P	Goulds WS0511B
1708P	Goulds PS52MF
1709P	Goulds WS0512B
1710P	Goulds WS1012B

### With 2 h.p. Grinder Pump

Item #	Pump Model
1724P	Goulds RGS2012