

# 750 Gallon Lowboy Septic Tank

Weight: 5600 lbs.  
 Item # 2024 Regular Duty  
 Item # 2128 H-20

## General Notes:

### Concrete Specifications:

- 1) 4000 psi @ 28 Days
- 2) 4%-6% Entrained Air
- 3) Tank Penetrations are integrally cast
- 4) Designed for HS-10 Wheel Loading
- 5) All joints sealed with butyl rubber joint sealant

### Septic Tank Information:

- 1) Tanks Should be pumped every 3-5 years
- 2) Center access covers should have risers to bring cover access to grade.
- 3) Tanks can be vacuum tested at an additional cost.

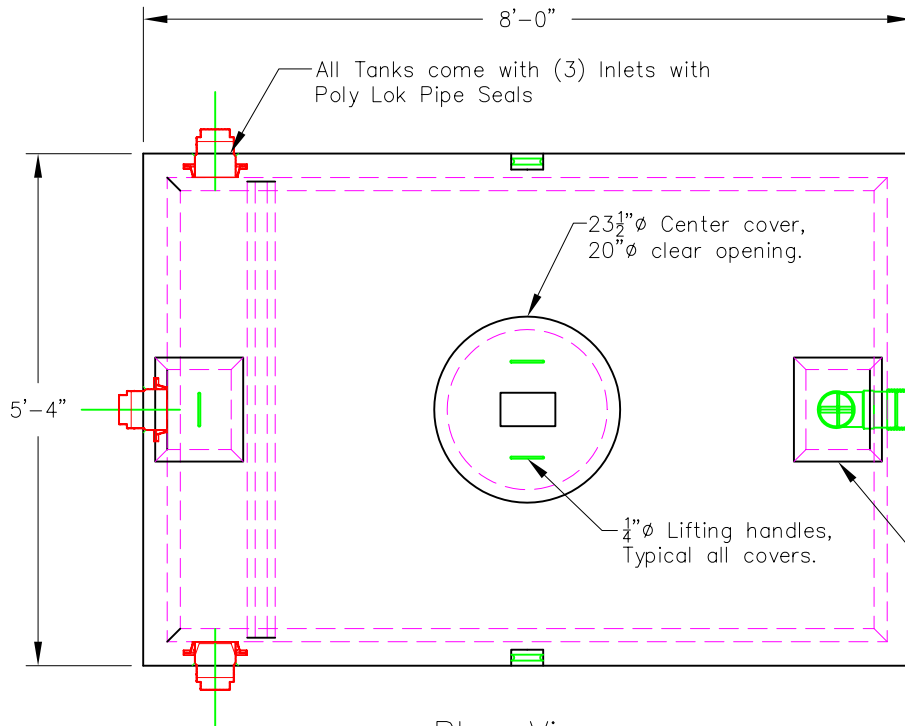

Plan View

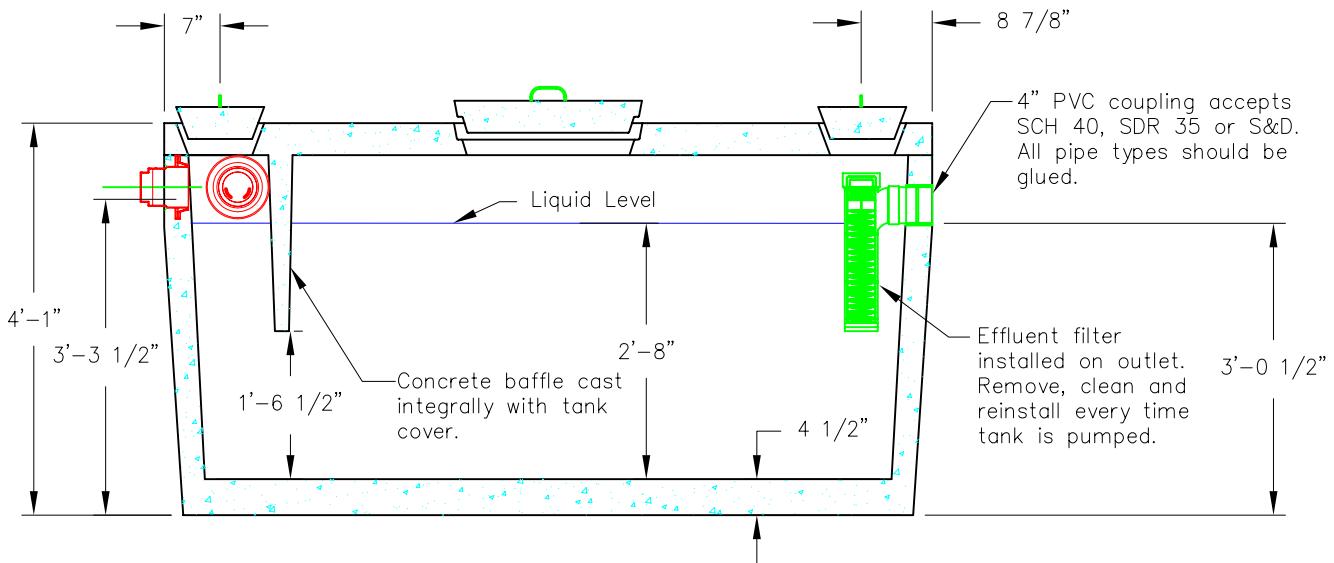

Section View



# American Concrete Industries

1022 Minot Ave. Auburn, ME / 1717 Stillwater Ave. Veazie, ME  
 Tel: 207-784-1388 / Tel: 207-947-8334

Last Revised:  
01/06

PG. XXX