

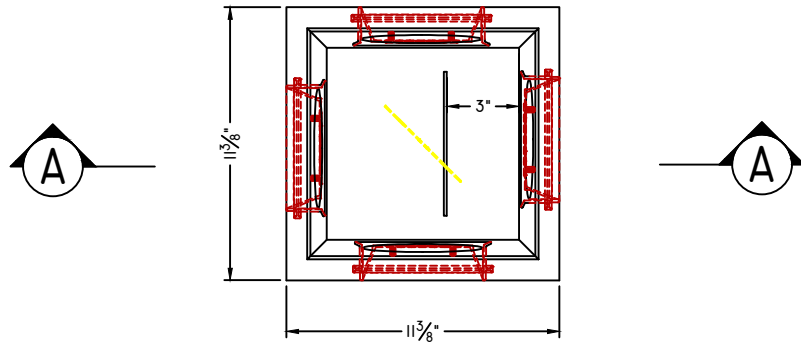

## 3 OUTLET DISTRIBUTION BOX (D-Box)

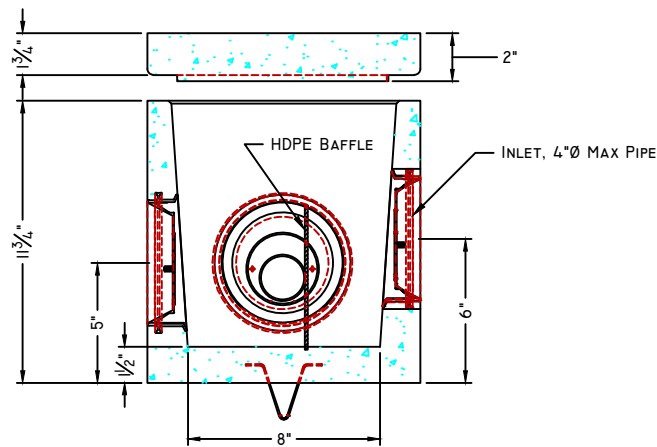

**PLAN VIEW**



**SECTION A-A**

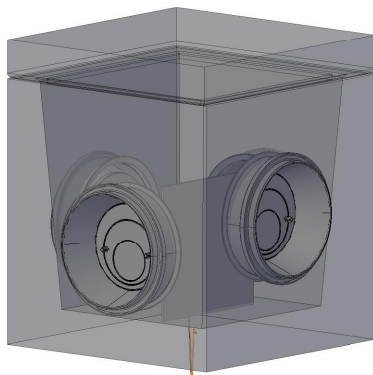

**CONCEPTUAL VIEW**

SCALE: NTS

**Manufacturing Notes**

- 1.1. CONCRETE COMPRESSIVE STRENGTH: 4,000PSI @ 28 DAYS
- 1.2. AIR ENTRAINMENT: 4-6%
- 1.3. GRADE 60 REINFORCEMENT & STRUCTURAL FIBER REINFORCED
- 1.4. NEVER USE SEPTIC CLEANING AGENTS
- 1.5. DESIGNED FOR PEDESTRIAN LOAD RATING ONLY
- 1.6. ALL PIPE SEAL PENETRATIONS ARE INTEGRALLY CAST
- 1.7. FLOW EQUALIZERS RECOMMENDED FOR EQUAL BED LOADING

**Physical Specifications:**

Cover Weight: 22 lbs  
 Base Weight: 55 lbs  
 Total Weight: 77 lbs